

# Installation Instructions

For set # 16-3104 / 16-3109



1131 VIA CALLEJON, SAN CLEMENTE, CA 92673

**Note: This set will not fit 88 Civic/CRX with stamped steel lower control arm.**

It is recommended that if you are unfamiliar with this type of work that you refer to a qualified service center specializing in this type of work. It is also recommended that if you choose to do this work yourself that a factory service manual be obtained for the proper procedures pertaining to removal, replacement and proper torque specifications for your vehicle. This instruction set is intended as a guideline for the safe installation of Energy Suspension's polyurethane bushings, once you have removed the factory components from your vehicle.

1. Properly support the vehicle on the frame.
2. Disconnect the end link from the control arm if so equipped. Remove the inner pivot bolt and loosen the outer pivot bolt (wheel side). Remove the lower strut mount bolt. Remove the lower control arm.
3. Press out the rubber bushing and shells from the inner and outer pivot ends. A hydraulic press will be needed. Clean and lubricate the inside of the control arms (where the shells were). Grease all sides of the bushing that contact metal.
4. Install the bushings. There are three bushing for this location. Two will be the same and one is different. Install the bushing with the flange first then install the bushing without the flange next. Install the remaining flanged bushing. Grease the sleeve and install the sleeve. See diagram. Reassemble the control arm onto the vehicle.
5. Tighten all fasteners to factory specs.
6. Realign vehicle.



**A hydraulic press was used to remove the original bushing, including the outer metal casing the rubber is bonded to. The inside diameter of the control arm in set # 16.3104 is  $\varnothing$  31mm (1.220") and set # 16.3109 is  $\varnothing$  35mm (1.378"). Go about .050" smaller when pressing out the bushing.**

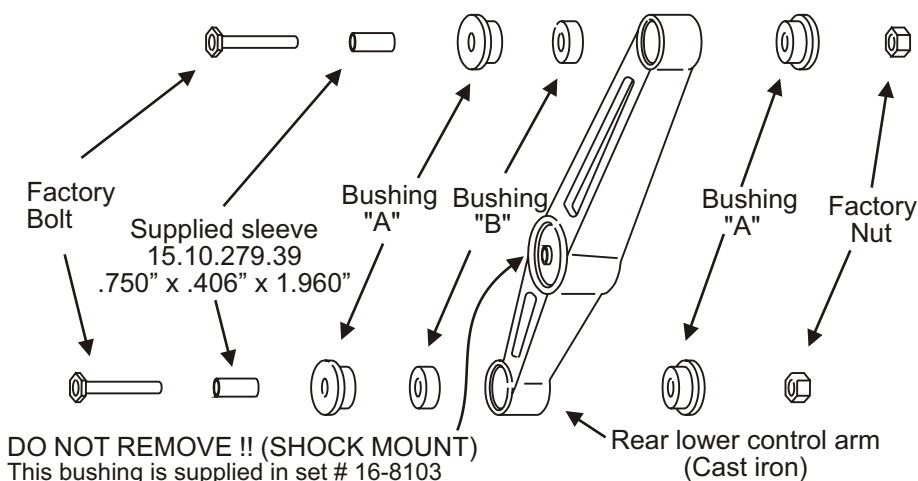

Set #	Bushing "A"	Bushing "B"
16-3104	2269	3283
16-3109	2301	3288

**17140**

3/25/97 KN  
Updated 18/FEB/02 BRH  
Updated 30/MAY/03 BRH

© 2003 Energy Suspension. All rights reserved.  
May not be reproduced, in any form, or by any means,  
without the written consent of Energy Suspension.