

Installation Instructions

Chevrolet Pickup, Dodge Pickup, Ford F-100, F-150, F-250, F-350, GMC Pickup

Part Numbers:
51017

Equipment Required: Center punch, Clamps,
Files-Round & Flat

Fastener Kit: 51017-051

Wrenches: 3/4, 13/16, 7/8, 13mm, 18mm, 19mm

Drill Bits: 3/16(.187), 9/32(.281), 1/2(.500), 17/32(.531)

Do Not Exceed Lower of Towing Vehicle
Manufacturer's Rating or

Hitch type	Max Gross Trailer WT (LB)	Max Tongue WT (LB)
Weight Distributing	10,000 (4540 Kg)	1000 (454 Kg)
Weight Carrying Ball Mount	5000 (2270 Kg)	500 (227 Kg)

Rivet clearance for 1988 to present Chevy Pickups only. Other models use spacers to space down for rivet clearance.

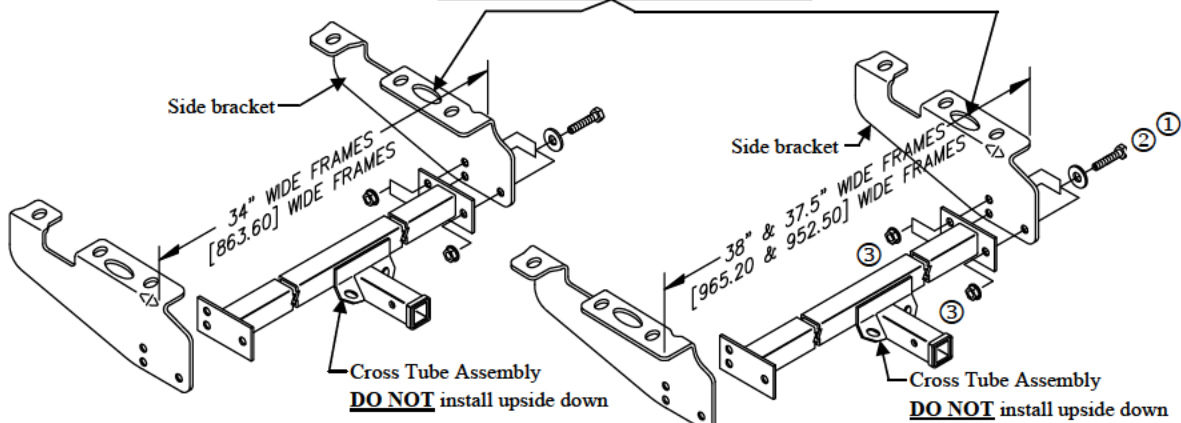

①	Qty. (6)	Bolt 1/2-20 X 1.50	⑧	Qty. (4)	Spacer 1/4 X 1.00 X 2.00
②	Qty. (8)	Hardened Flat Washer	⑨	Qty. (2)	Bolt M12 X 1.75 X 45
③	Qty. (6)	Flanged Locknut 1/2-20	⑩	Qty. (2)	Spacer 7/16 X 1.00 X 2.00
④	Qty. (4)	Bolt 1/2-13 X 2.00	⑪	Qty. (2)	Nut M12 X 1.75
⑤	Qty. (12)	Spacer 1/4 X 1.50 X 2.00	⑫	Qty. (2)	Lock Washer 1/2
⑥	Qty. (6)	Conical Washer 1/2	⑬	Qty. (2)	Bolt 1/2-13 X 2.25
⑦	Qty. (6)	Hex Nut 1/2-13			

- Remove pickup truck spare tire at end of frame from its under bed mounting. This is not required for each installation but will make receiver installation easier. It is to be reinstalled when installation is complete.
- Measure the outside width of the frame. It should measure approximately 34" or 37-1/2" or 38".
- Assemble the side brackets to the cross tube assembly as shown above. The bracket flanges point outboard for 37-1/2" and 38" wide frames. The bracket flanges point inboard for 34" wide frames. Slots in the cross tube must line up with the holes in the side brackets. (**Caution: Do Not drill new holes in any receiver part.**)
- Install the 1/2-20 x 1-1/2 hex bolts, hardened flat washers, and flange locknuts as shown above. **Do not** substitute regular nuts for the locknuts. Tighten all 1/2-20 fasteners with torque wrench to 90 Lb.-Ft. (122 N*M)
- Read the General Notes and then continue installation by following the instructions for your particular vehicle application which is listed on the following pages.

Tighten all 1/2-20 GR5 fasteners with torque wrench to 90 Lb.-Ft. (122 N*M)

Tighten all 1/2-13 GR5 fasteners with torque wrench to 75 Lb.-Ft. (102 N*M)

Tighten all M12 CL10.9 fasteners with torque wrench to 75 Lb.-Ft. (102 N*M)

Note: check hitch frequently, making sure all fasteners and ball are properly tightened. If hitch is removed, plug all holes in trunk pan or other body panels to prevent entry of water and exhaust fumes. A hitch or ball which has been damaged should be removed and replaced. Observe safety precautions when working beneath a vehicle and wear eye protection. Do not cut access or attachment holes with a torch.

This product complies with safety specifications and requirements for connecting devices and towing systems of the state of New York, V.E.S.C. Regulation V-5 and SAE J684.

Chevrolet & GMC Pickup Trucks with 34" frames

(Does not fit units with 6' bed or 4WD with heavy duty suspension)

1. Tighten the 1/2-20 hex bolts installed as shown on page 1 to 90 lb.-Ft. (122 N*M)
2. Note: 1981 and later Chevrolet & GMC applications with step bumpers require the removal of support brackets to the frame. These brackets must be retained for reinstallation upon removal of the receiver. The step bumper should not be used for towing with these support brackets removed.
3. Position and center the receiver assembly on vehicle frame. Rearmost slot in receiver should not be located closer than 3/4" from the end of the frame. To clear rivets in the frame, place a spacer between side brackets and vehicle frame at each attachment. Clamp receiver to the frame. Note: On some units even with the spacers in place, the top of the rivets may have to be ground or filed off to ensure that the attaching surfaces sit flat on the frame.
4. Using the slots in the side brackets as templates, center punch and drill six (6) 1/2" diameter holes. See **General Notes** regarding the use of existing holes.
5. Install fasteners in each side as shown.

Part Numbers:
51017

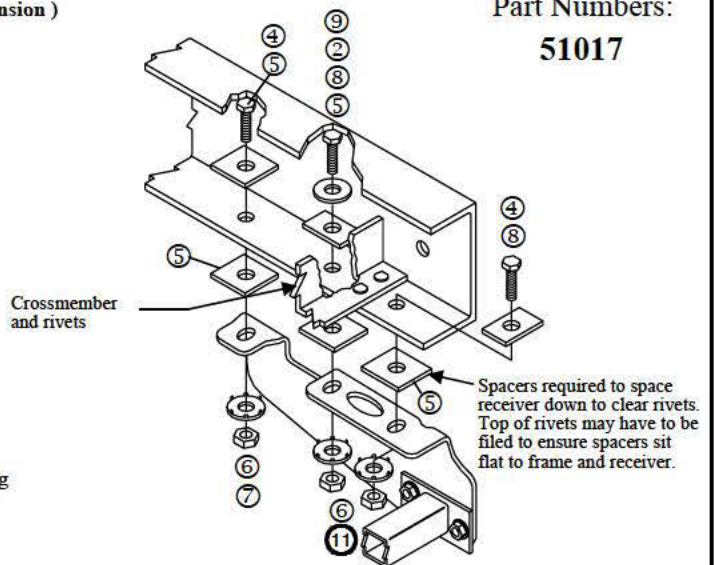

①	Qty. (6)	Bolt 1/2-20 X 1.50	⑧	Qty. (4)	Spacer 1/4 X 1.00 X 2.00
②	Qty. (8)	Harden Flat Washer	⑨	Qty. (2)	Bolt M12 X 1.75 X 45
③	Qty. (6)	Flanged Locknut 1/2-20	⑩	Qty. (2)	Spacer 7/16 X 1.00 X 2.00
④	Qty. (4)	Bolt 1/2-13 X 2.00	⑪	Qty. (2)	Nut M12 X 1.75
⑤	Qty. (12)	Spacer 1/4 X 1.50 X 2.00	⑫	Qty. (2)	Lock Washer 1/2
⑥	Qty. (6)	Conical Washer 1/2	⑬	Qty. (2)	Bolt 1/2-13 X 2.25
⑦	Qty. (6)	Hex Nut 1/2-13			

1988 & Later Model Chevrolet & GMC Pickup Trucks with 37-1/2" frames

Note: On units equipped with an extended cab and 6' bed, the spare tire will have to be relocated elsewhere on the vehicle.

1. On 6' bed units, remove and relocate ground wire and ground wire bolt located on driver's side frame rail.
2. If vehicle is equipped with factory installed step bumper, remove the M12 hex bolts from each end of the frame and discard.
3. Raise receiver into position, centering rearmost slot over existing holes in frame. On units with a 6' bed, the large 1" x 2" slot will be positioned over a bolt on the passenger's side and a rivet on the driver's side.
4. Vehicles w/factory installed step bumper: Install M12 x 1.75 x 45mm hex bolt and conical washer through side bracket into frame, threading into existing weldnut as shown.
5. Vehicles W/O factory installed step bumper: Install M12 x 1.75 x 45mm hex bolt and conical washer through side bracket and frame and fasten with block, lock washer and M12 x 1.75 nut.
6. Center receiver crosstube assembly on vehicle and tighten the 1/2-20 hex bolts installed as shown on page 1 to 90 lb.-Ft.(122 N*M).
7. Due to vehicle variation, center attachment hole in frame may have to be enlarged to 1/2". See **General Notes** regarding use of existing holes.
8. Install fasteners in center and forward holes on each side as shown.

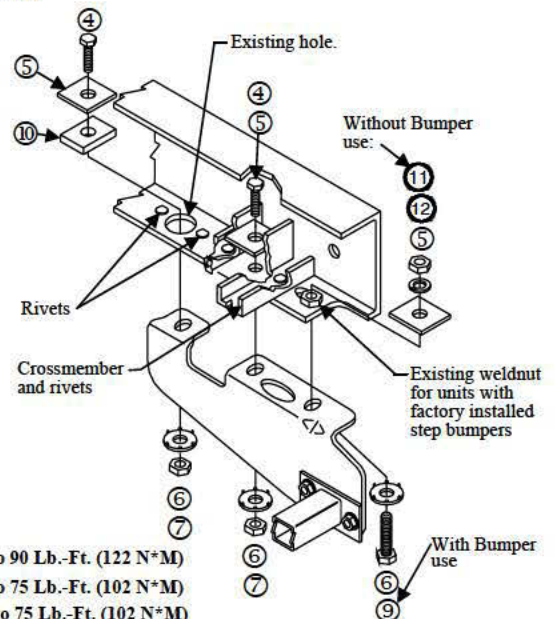

Tighten all 1/2-20 GR5 fasteners with torque wrench to 90 Lb.-Ft. (122 N*M)

Tighten all 1/2-13 GR5 fasteners with torque wrench to 75 Lb.-Ft. (102 N*M)

Tighten all M12 CL10.9 fasteners with torque wrench to 75 Lb.-Ft. (102 N*M)

Note: check hitch frequently, making sure all fasteners and ball are properly tightened. If hitch is removed, plug all holes in trunk pan or other body panels to prevent entry of water and exhaust fumes. A hitch or ball which has been damaged should be removed and replaced. Observe safety precautions when working beneath a vehicle and wear eye protection. Do not cut access or attachment holes with a torch.

This product complies with safety specifications and requirements for connecting devices and towing systems of the state of New York, V.E.S.C. Regulation V-5 and SAE J684.

Ford F-Series - Full Size Pickup Trucks
1979 and earlier 34" & 38" wide frame Ford Cab & Chassis

Note: Cab & Chassis Only

To install this receiver there must be 18" of unobstructed frame along with clearance for the cross-tube assembly at the center of the vehicle.

1. Tighten the 1/2-20 hex bolts installed as shown on page 1 to 90 lb.-Ft.(122 N*M)
2. Position and center the receiver assembly on vehicle frame. Rearmost slot in receiver should not be located closer than 3/4" from the end of the frame. To clear the rivets in the frame place a spacer between side brackets and vehicle frame at each attachment. Clamp receiver to the frame.

Note: On some units even with spacers in place, the top of the rivets may have to be ground or filed off to ensure that the attaching surfaces sit flat on the frame.

3. Using the slots in the side brackets as templates, center punch and drill six (6) 1/2" diameter holes. See **General Notes** regarding the use of existing holes.
4. Install fasteners in each side as shown.

Part Numbers:
51017

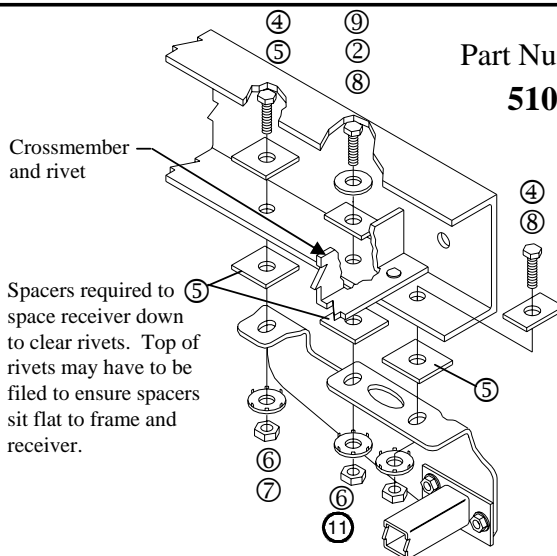

①	Qty. (6)	Bolt 1/2-20 X 1.50	⑧	Qty. (4)	Spacer 1/4 X 1.00 X 2.00
②	Qty. (8)	Hardened Flat Washer	⑨	Qty. (2)	Bolt M12 X 1.75 X 45
③	Qty. (6)	Flanged Locknut 1/2-20	⑩	Qty. (2)	Spacer 7/16 X 1.00 X 2.00
④	Qty. (4)	Bolt 1/2-13 X 2.00	⑪	Qty. (2)	Nut M12 X 1.75
⑤	Qty. (12)	Spacer 1/4 X 1.50 X 2.00	⑫	Qty. (2)	Lock Washer 1/2
⑥	Qty. (6)	Conical Washer 1/2	⑬	Qty. (2)	Bolt 1/2-13 X 2.25
⑦	Qty. (6)	Hex Nut 1/2-13			

Ford F-Series Full Size Pickup Trucks 1980 and later 38" wide frames
Does not fit Flareside units with fiber glass valance panels

Note: Hitch Cannot be installed with 16" spare tire. Spare tire must be relocated.

1. Position and center the receiver assembly on vehicle frame. To clear rivets in the frame, place two (2) spacers between side brackets and vehicle frame at first and center attachments. Clamp receiver to the frame.
2. Using the rearmost slots in the side brackets as templates, center punch and drill two (2) 1/2" diameter holes. See **General Notes** regarding drilling holes.
3. Install fasteners in rearmost slot each side as shown making sure that two (2) spacers are placed between side bracket and frame. Tighten to 75 lb.-Ft.(102 N*M)
4. Center receiver cross-tube assembly on vehicle.
5. With bolts in rearmost holes tightened, force forward attachment flanges outboard such that inboard portion of the slots are centered on the frame. Using the forward attaching slots as templates, center punch and drill two (2) 1/2" diameter holes. It is important that drilled hole is centered on the frame flange to ensure adequate material between hole and inside edge of frame.
6. Install fasteners in forward attachment as shown.
7. Using the center attaching slots as templates, center punch and drill two (2) 1/2" diameter holes. Install fasteners through center attachment as shown making sure that the two (2) spacers are between side brackets and frame.

Tighten all 1/2-20 GR5 fasteners with torque wrench to 90 Lb.-Ft. (122 N*M)

Tighten all 1/2-13 GR5 fasteners with torque wrench to 75 Lb.-Ft. (102 N*M)

Tighten all M12 CL10.9 fasteners with torque wrench to 75 Lb.-Ft. (102 N*M)

Note: check hitch frequently, making sure all fasteners and ball are properly tightened. If hitch is removed, plug all holes in trunk pan or other body panels to prevent entry of water and exhaust fumes. A hitch or ball which has been damaged should be removed and replaced. Observe safety precautions when working beneath a vehicle and wear eye protection. Do not cut access or attachment holes with a torch.

This product complies with safety specifications and requirements for connecting devices and towing systems of the state of New York, V.E.S.C. Regulation V-5 and SAE J684.

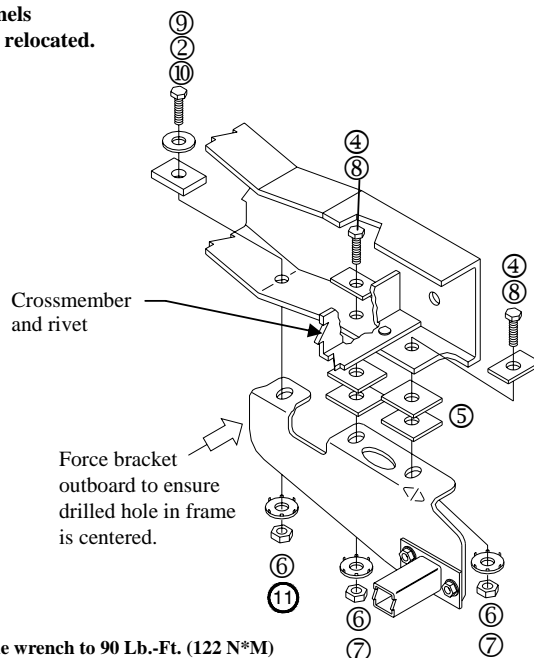

Dodge Ram Pickup Truck - Full size - 1994-Present
No drilling for 8 ft. Bed units; Drill two (2) holes for 6 ft. Bed units
Does not fit with heavy duty suspensions

Part Numbers:
51017

1. Remove exhaust hanger bracket from side of frame. -
Not Required after 1997.
2. Raise receiver into position centering rearmost hole over existing hole (not large hole) at end of the frame. To clear lip on bottom of frame, place two spacers between side bracket and frame at each attachment point. Drill forward hole on 6 ft. Bed units.
3. On 1999 units, the center attachment hole does not line up with the existing hole in the vehicle frame. Enlarge hole in the frame to match the hole in the side bracket.
4. Install 1/2-13 bolts and fasteners in each side bracket as shown.
5. Center receiver crosstube assembly on vehicle and tighten 1/2-20 hex bolts installed as shown on page 1 to 90 lb.-Ft.(122 N*M)
6. Exhaust reinstallation - If required
8 ft. Bed units - Drill hole in exhaust bracket to reposition bracket 1" forward as shown below. Reinstall bracket.
6 ft. Bed units - Reinstall exhaust hanger bracket.

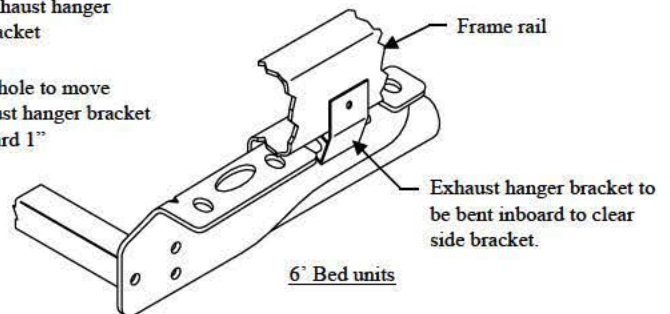
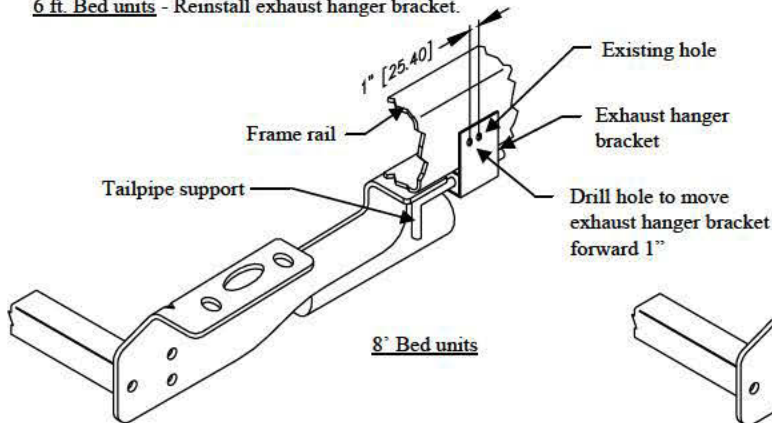
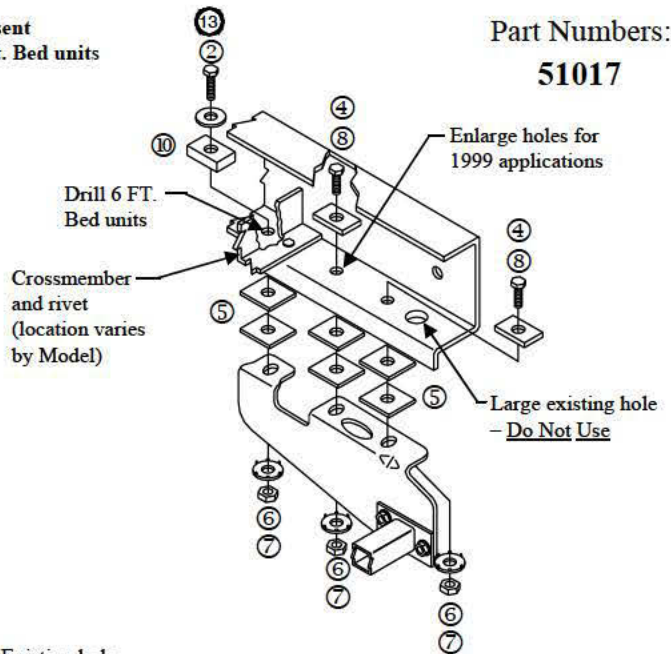

①	Qty. (6)	Bolt 1/2-20 X 1.50	⑧	Qty. (4)	Spacer 1/4 X 1.00 X 2.00
②	Qty. (8)	Hardened Flat Washer	⑨	Qty. (2)	Bolt M12 X 1.75 X 45
③	Qty. (6)	Flanged Locknut 1/2-20	⑩	Qty. (2)	Spacer 7/16 X 1.00 X 2.00
④	Qty. (4)	Bolt 1/2-13 X 2.00	⑪	Qty. (2)	Nut M12 X 1.75
⑤	Qty. (12)	Spacer 1/4 X 1.50 X 2.00	⑫	Qty. (2)	Lock Washer 1/2
⑥	Qty. (6)	Conical Washer 1/2	⑬	Qty. (2)	Bolt 1/2-13 X 2.25
⑦	Qty. (6)	Hex Nut 1/2-13			

Tighten all 1/2-20 GR5 fasteners with torque wrench to 90 Lb.-Ft. (122 N*M)
Tighten all 1/2-13 GR5 fasteners with torque wrench to 75 Lb.-Ft. (102 N*M)
Tighten all M12 CL10.9 fasteners with torque wrench to 75 Lb.-Ft. (102 N*M)

Note: check hitch frequently, making sure all fasteners and ball are properly tightened. If hitch is removed, plug all holes in trunk pan or other body panels to prevent entry of water and exhaust fumes. A hitch or ball which has been damaged should be removed and replaced. Observe safety precautions when working beneath a vehicle and wear eye protection. Do not cut access or attachment holes with a torch.

This product complies with safety specifications and requirements for connecting devices and towing systems of the state of New York, V.E.S.C. Regulation V-5 and SAE J684.

Dodge Pickup Truck - Full Size 1967 - 1993

Spare tire carrier will have to be modified to retain under vehicle stowage.
Spare tire can also be relocated elsewhere on the vehicle.

Installation depends on vehicle configuration:

Configuration 1: 8' bed, 2 & 4 wheel drive, regular & extended cab

Configuration 2: 6' bed, 2 & 4 wheel drive

Configuration 1 - All holes require drilling

1. Position and center the receiver assembly on vehicle frame.
Locate rear-most slot in receiver 1" forward from the edge of the large existing hole at the end of the frame. This is required so that the forward attaching flange does not ride on the crossmember rivet. Clamp receiver to the frame.
2. Center receiver cross-tube assembly on vehicle and tighten the 1/2-20 hex bolts installed as shown on page 1 to 90 lb.-Ft. (122 N*M)
3. Using slots in brackets as templates, center punch and drill six (6) 1/2" diameter holes in frame. Install fasteners as shown for configuration 1.

Configuration 2 - uses existing holes

1. Position and center receiver over large existing hole at the end of the frame. Center and forward slots will match with existing holes. Secure with fasteners as shown for configuration 2.
2. Center receiver cross-tube assembly on vehicle and tighten the 1/2-20 hex bolts installed as shown on page 1 to 95 lb.-Ft. (129 N*M)

Tighten all 1/2-20 GR5 fasteners with torque wrench to 90 Lb.-Ft. (122 N*M)
Tighten all 1/2-13 GR5 fasteners with torque wrench to 75 Lb.-Ft. (102 N*M)
Tighten all M12 CL10.9 fasteners with torque wrench to 75 Lb.-Ft. (102 N*M)

Part Numbers:
51017

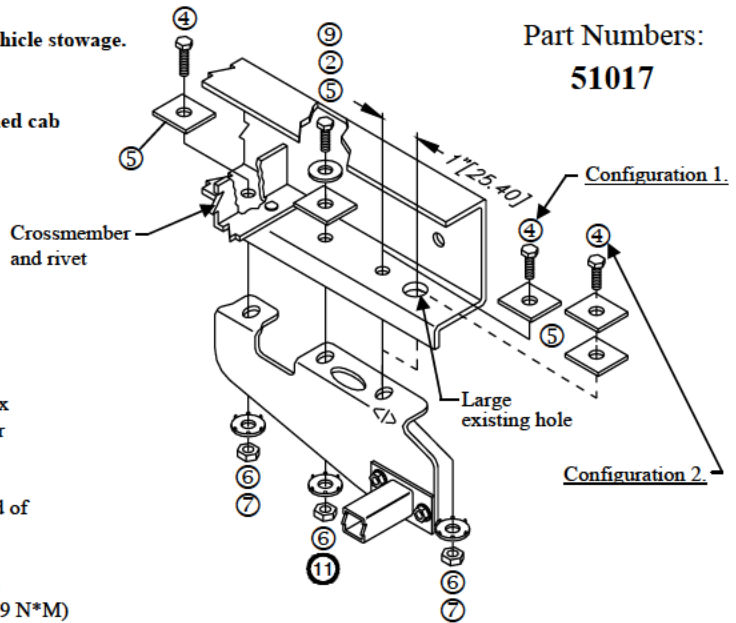

①	Qty. (6)	Bolt 1/2-20 X 1.50	⑧	Qty. (4)	Spacer 1/4 X 1.00 X 2.00
②	Qty. (8)	Hardened Flat Washer	⑨	Qty. (2)	Bolt M12 X 1.75 X 45
③	Qty. (6)	Flanged Locknut 1/2-20	⑩	Qty. (2)	Spacer 7/16 X 1.00 X 2.00
④	Qty. (4)	Bolt 1/2-13 X 2.00	⑪	Qty. (2)	Nut M12 X 1.75
⑤	Qty. (12)	Spacer 1/4 X 1.50 X 2.00	⑫	Qty. (2)	Lock Washer 1/2
⑥	Qty. (6)	Conical Washer 1/2	⑬	Qty. (2)	Bolt 1/2-13 X 2.25
⑦	Qty. (6)	Hex Nut 1/2-13			

General Notes

1. Attachment holes must be drilled for most applications. In some cases existing holes in frame may line up with some of the holes in the receiver side brackets. When holes do not match precisely, file or grind material from the vehicle frame to match the hole in the receiver side bracket.

Warning: do not correct hole mismatch by drilling, because drill can suddenly bind causing drill motor to "kick back" or drill bit to break, possibly resulting in personal injury.

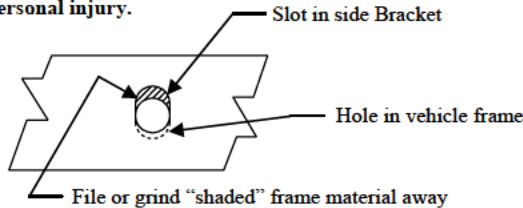

2. When positioning receiver on vehicle frame, make sure that the cross-tube assembly does not contact any gas tank supports or spare tire hanger brackets if vehicle is so equipped.
3. Be careful to avoid drilling into the fuel tank, wires and fuel or brake lines that are sometimes located inside the vehicle frame sections.
4. Deburr all edges of all holes drilled through frame and/or crossmembers. Proper deburring will ensure that fasteners and side brackets will sit flat.
5. Always wear safety glasses when drilling.
6. License plate mounting bracket will have to be relocated on vehicles without a factory installed bumper.

Note: check hitch frequently, making sure all fasteners and ball are properly tightened. If hitch is removed, plug all holes in trunk pan or other body panels to prevent entry of water and exhaust fumes. A hitch or ball which has been damaged should be removed and replaced. Observe safety precautions when working beneath a vehicle and wear eye protection. Do not cut access or attachment holes with a torch.

This product complies with safety specifications and requirements for connecting devices and towing systems of the state of New York, V.E.S.C. Regulation V-5 and SAE J684.