

Installation Instructions

Part Numbers:

Ford Van (Full Size)

51007

All models incl. Vans with Factory Step Bumper**

Does Not Fit Pre-1992 E-350 or 124" Wheelbase Models

Do Not Exceed Lower of Towing Vehicle
Manufacturer's Rating or

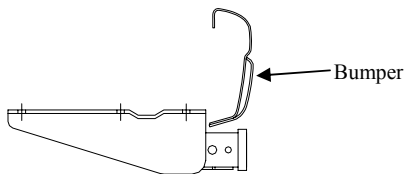

Hitch Shown In Proper Position

Equipment Required:

Fastener Kit: 51007-051

Wrenches: 3/4, 7/8

Drill Bits: 1/2"

Hitch type	Max Gross Trailer WT (LB)	Max Tongue WT (LB)
Weight Distributing	10,000 (4540 Kg)	1000 (454 Kg)
Weight Carrying Ball Mount	5000 (2270 Kg)	500 (227 Kg)

Wiring Access Location: SUV1, SUV2

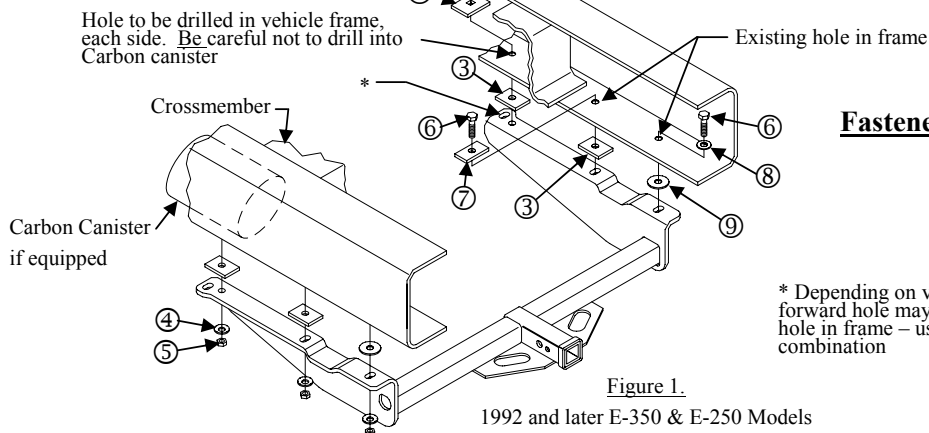

Fasteners typical both sides

* Depending on vehicle configuration, forward hole may line up with existing hole in frame – use same fastener combination

Figure 1.

1992 and later E-350 & E-250 Models

①	Qty. (2)	Carriage Bolt 1/2-13 X 1.75	⑥	Qty. (4)	Hex Bolt 1/2-13 X 1.75
②	Qty. (2)	Block .25 X 1.50 X 2.00	⑦	Qty. (2)	Block .25 X 1 X 2
③	Qty. (4)	Block .25 X 1.50 X 2.00	⑧	Qty. (2)	Flat Washer 1/2 (Small)
④	Qty. (6)	Conical Washer 1/2	⑨	Qty. (2)	Flat Washer 1/2 (Large)
⑤	Qty. (6)	Hex nut 1/2-13			

1992 and Later Models – see Figure 1 & 2 Modification of vehicle exhaust may be necessary on vehicle with twin tip exhaust.

**Note: 1992 and later vehicles with factory step bumpers required 12" long ball mount or weight distributing shank.

Note: Wiring harness is located inside vehicle frame. Reposition prior to drilling

- If present, lower carbon canister from driver's side frame rail.
- Lower spare tire. Note: Relocation of under vehicle spare tire is no required. Tire may have to be repositioned slightly forward to avoid contact with receiver tube.
- Remove all but a thin layer of undercoating from attaching surfaces.
- Disconnect factory installed optional driver's side trailer wiring connector from bumper.
- Position receiver on vehicle as shown, lining up with existing holes in frame.
- Loosely install bolts, blocks (depending on model: see Figures 1 & 2), flat washers, conical washers and nuts.
- Using receiver as a template, drill a 1/2" hole in each frame rail and install 1/2" bolts, block (depending on model), conical washers and nuts. Note: if existing hole is present, forward slot may be used in place of drilled hole.
- Reinstall factory trailer wiring connector to clear receiver.
- Raise spare tire while positioning tire forward on vehicle. Check for clearance between differential and bracket lines.
- Reattach carbon canister if present – carbon canister must not contact bolt head. If it does loosen canister fasteners and reposition the canister to ensure clearance with bolt head.

Tighten all 1/2-13 fasteners with torque wrench to 75 Lb.-Ft. (102 N*M)

Note: check hitch frequently, making sure all fasteners and ball are properly tightened. If hitch is removed, plug all holes in trunk pan or other body panels to prevent entry of water and exhaust fumes. A hitch or ball which has been damaged should be removed and replaced. Observe safety precautions when working beneath a vehicle and wear eye protection. Do not cut access or attachment holes with a torch.

This product complies with safety specifications and requirements for connecting devices and towing systems of the state of New York, V.E.S.C. Regulation V-5 and SAE J684.

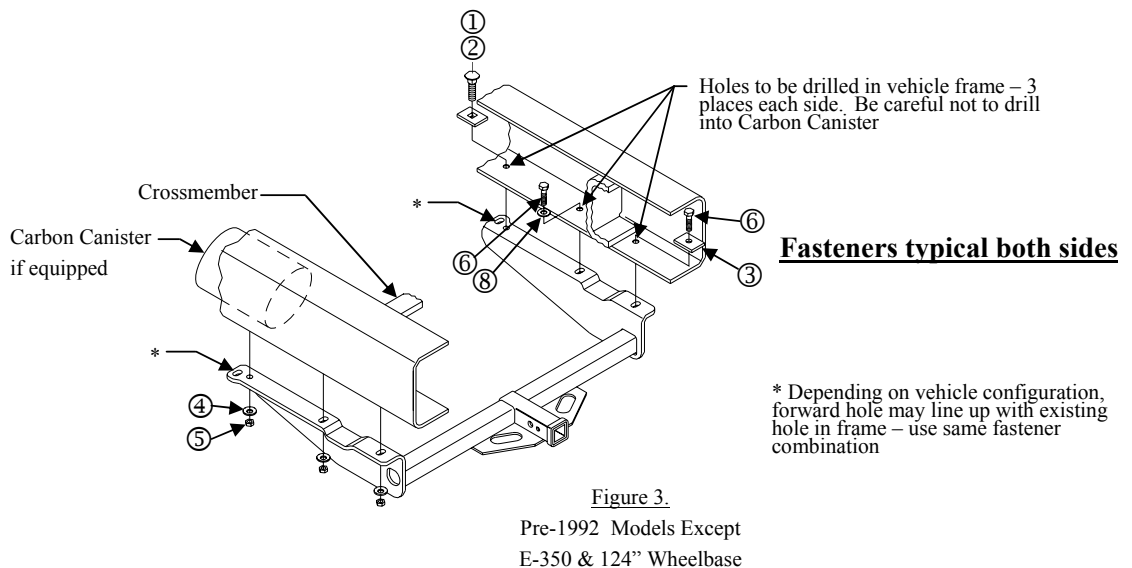
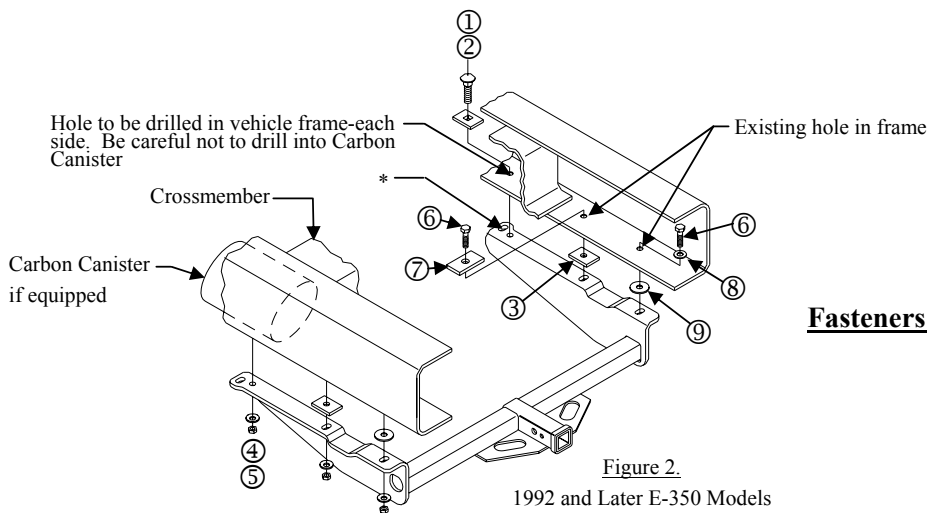

Pre-1992 Models – see Figure 3 (Does Not Fit E-350 or 124" Wheelbase)

** **Note:** 1992 and later vehicle with factory step bumpers require 12" long ball mount or weight distributing shank

Note: On some models, tail pipe and/or tail pipe bracket may have to be relocated and/or modified.

1. If present, lower carbon canister from driver's side frame rail.
2. Remove all but a thin layer of undercoating from attaching surfaces.
3. Center receiver on vehicle so crossmember frame rivet will fit into step in side bracket.
4. Using hitch as a template, drill three (3) holes per side through frame with 1/2" drill bit.
5. Install fasteners as shown.
6. Reattach carbon canister if present – carbon canister must not contact bolt head. If it does loosen canister fasteners and reposition the canister to ensure clearance with bolt head.

Tighten all 1/2-13 fasteners with torque wrench to 75 Lb.-Ft. (102 N*M)

Note: check hitch frequently, making sure all fasteners and ball are properly tightened. If hitch is removed, plug all holes in trunk pan or other body panels to prevent entry of water and exhaust fumes. A hitch or ball which has been damaged should be removed and replaced. Observe safety precautions when working beneath a vehicle and wear eye protection. Do not cut access or attachment holes with a torch.

This product complies with safety specifications and requirements for connecting devices and towing systems of the state of New York, V.E.S.C. Regulation V-5 and SAE J684.