

CONTROL MODULE F152 (A)

©2009 WELLS Manufacturing, L.P.
All Rights Reserved. No portion of this manual may be reproduced without the written permission of Wells Manufacturing, L.P.

NOTES

1



If "SH" displays, check connections and retest. If there is no change, the module has failed.

2

3

**FOR ASSISTANCE CALL:
WELLS MANUFACTURING, L.P.
1-800-558-9770
FOR CUSTOMER SERVICE**

STEP 1: FIND CORRECT LEAD WIRE

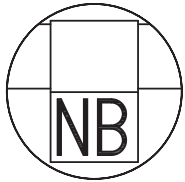

STEP 3: CONNECT TO TESTER

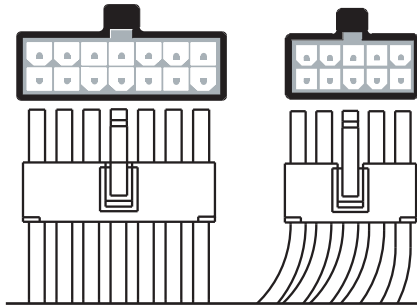

STEP 4: SETTING UP TESTER

Enter product select number "04" and press start to begin test.



STEP 2: MAKE CONNECTIONS TO PART (F152)

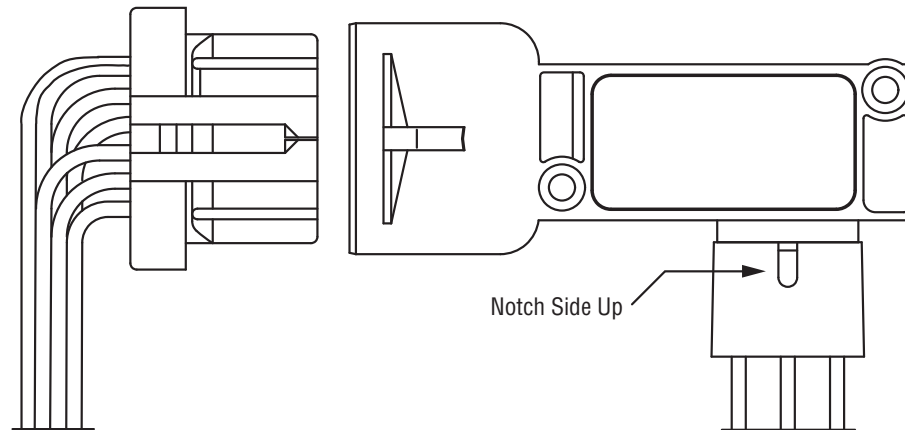

DANGER: Do not handle the module during or immediately after the test sequence, as electrical shocks and burns may occur.

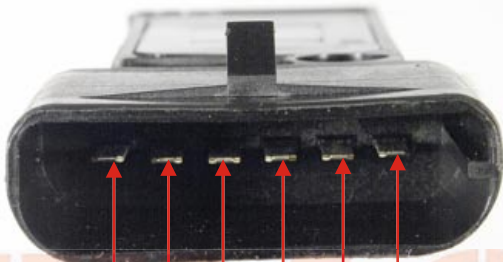

Ignition Ground

Coil Negative

Battery Voltage

IDM Signal

Spout

PIP Signal

PIP In

CMP Power

Ground

